

## MAINTENANCE MATTERS

Vol. 1 No. 16

# PRIMARY BLADE DRIVE V BELT REPLACEMENT

1) Ensure that the machine is well secured in position and the parking brake is **ENGAGED** before beginning work. Remove the ignition key and also disconnect the battery to ensure the machine cannot be accidentally started while maintenance is being undertaken.

2) Remove the belt cover from the bottom of the primary drive pulley found under the engine (3 Bolts).

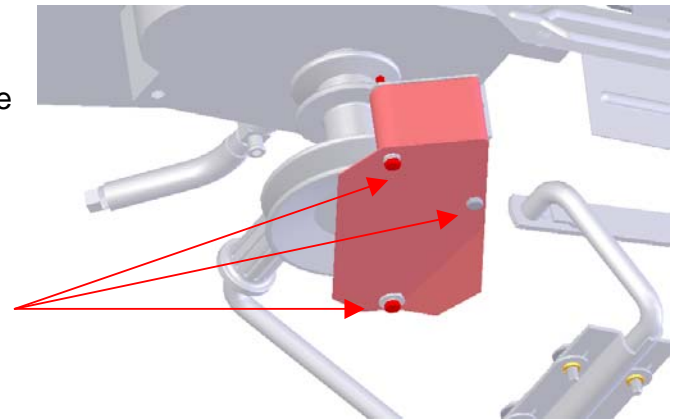

3) Ensure that the blade drive is **DISengaged** to remove the belt tension and then remove the blade drive belt from the drive pulley.

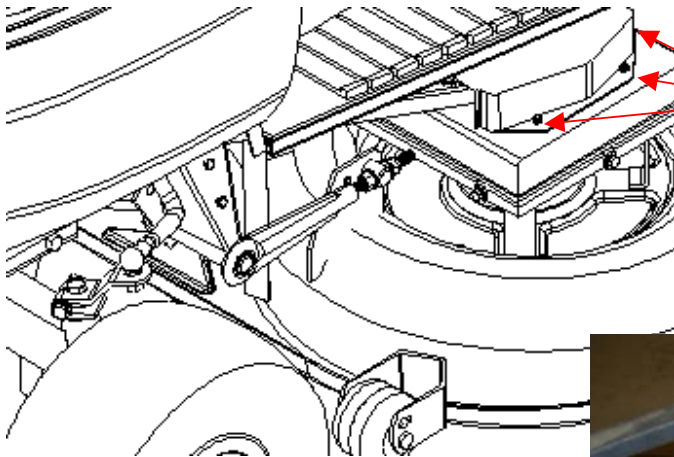

4) Move to the opposite end of the belt and remove the three small bolts retaining the upper blade belt cover on the Blade chassis to expose the primary blade drive V belt pulley.

5) Now the blade brake needs to be retracted from the pulley to enable removal of the drive belt. To do this first **ENGAGE** the blade drive lever on the dashboard (engages blades

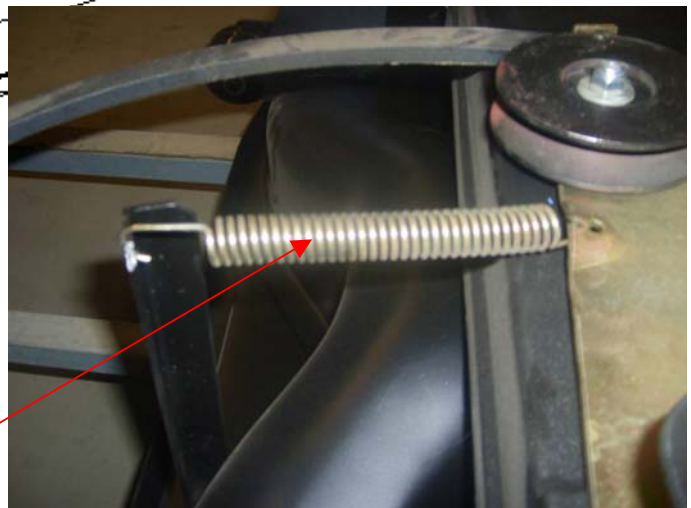

AND disengages blade brake) then remove the tensioning spring  
And if necessary use a long shaft screwdriver or some other lever to move the brake pad back further to allow the removal of the belt from the pulley.

- 6) Finally the belt tensioning pulley (Item 5 on page 56 of the manual) now needs to be removed so the belt can be removed and replaced. The pulley has to be removed from the tensioner plate, it is fitted to as it has 2 "lugs" that retain the belt and the belt cannot be removed until the pulley is lifted from its operation position.

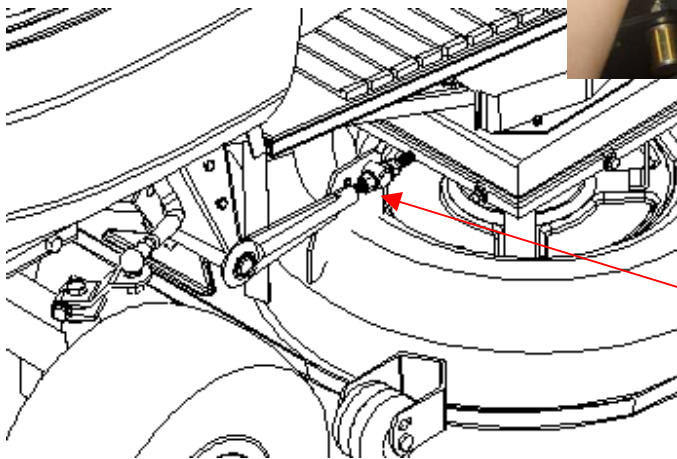
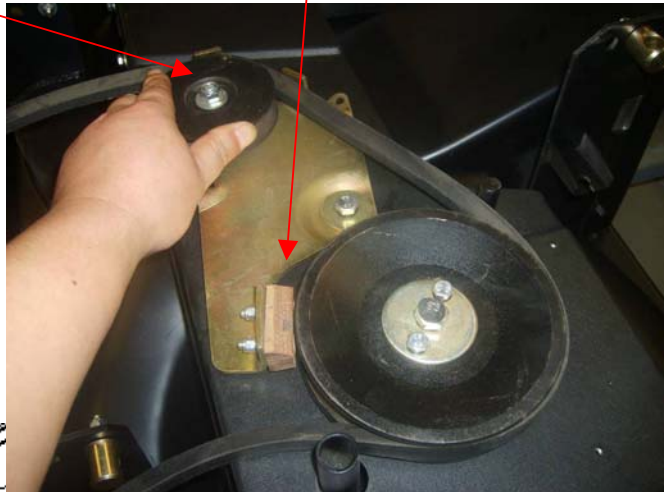

The Blade assembly position adjusters will likely need to be altered to enable fitting of a new belt. Move the deck positioning adjusters on both sides of the deck to bring the cutting deck assembly closer to the front of the mower (This brings the drive pulleys closer thus reducing the belt tension.)

Reverse the process to reassemble ensuring the cutting deck is repositioned with the adjusters to ensure the correct belt tension. Correct tension is set by adjusting and testing, adjusting and testing until the blades do not rotate when "disengaged" and the belt does not slip when the blades are engaged.

## HAPPY MOWING

© Machines Gadgets and Gizmows Ltd

[www.MGG.co.nz](http://www.MGG.co.nz)